

TR125 Manual TR125 Manual 250 Top Rollers



The ROEQ TR125 Manual is a manually adjustable top roller, developed for the MiR100/200 or 250, to carry out scheduled pick-up and delivery tasks between stationary conveyor stations.

All ROEQ top modules come with ROEQ Assist software that includes setup tools, making it easy for you to quickly get your solution up and running. The software creates missions and sets the robot footprint.

Specifications

Robot compatibility:

TR125 Manual: MiR100, MiR200
TR125 Manual 250: MiR250

ROEQ product compatibility:

DS Standalone, GuardCom System

Payload:

MiR100: 25kg / 55.1lbs
MiR200: 125kg / 276lbs
MiR250: 125kg / 276lbs

Size (l x w):

925mm x 580mm / 36.4 x 22.8

Height from floor to rollers:

TR125 Manual: 660mm-810 mm / 26-31.9
TR125 Manual 250: 600mm-750 mm / 23.6-29.5

Features

- Manually adjustable stroke of 200mm/7.87" – can be adjusted to fit existing conveyor stations
- Built-in barriers on rollers protect fingers
- Built-in position sensor confirms correct position of robot before transfer of goods
- Cargo sensors on the front and back ensure safe transfer and transport of cargo
- Compatible with ROEQ GuardCom system for additional safety and quick transfer to/from conveyor stations. Wireless communication without reliance on Wi-Fi

Roller area:

800mm x 485mm / 31.5 x 19.1

Weight:

TR125 Manual: 75kg/165lbs
TR125 Manual 250: 80kg/176lbs

Stroke:

150mm / 5.91"

Position when in transit:

Stays at constant height

Sensors:

Position sensor and cargo sensors





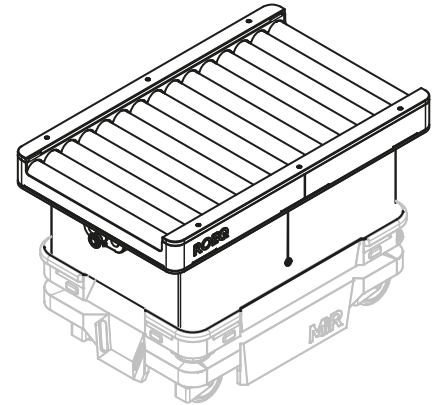
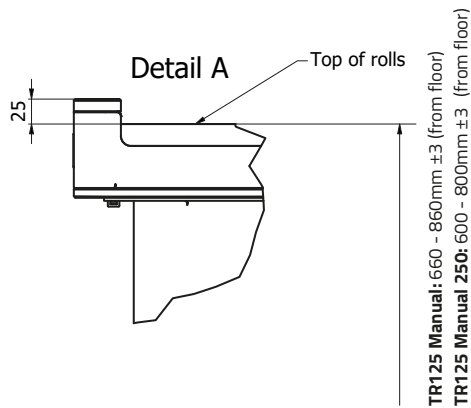
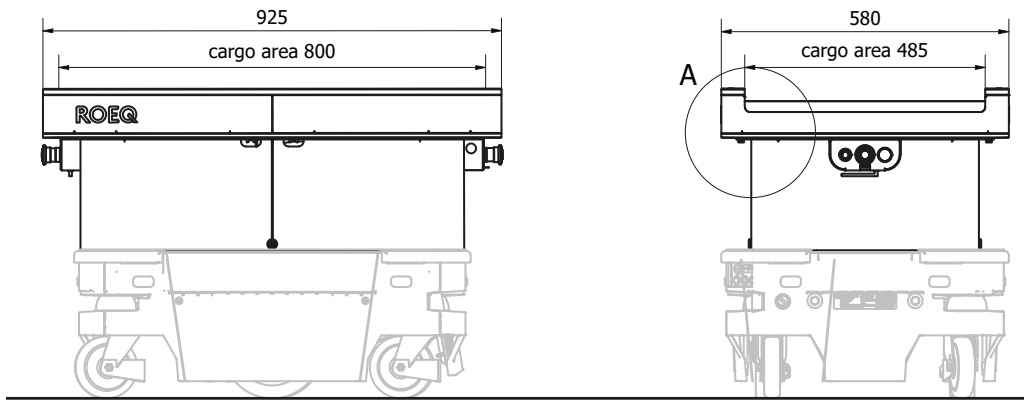

Roller speed:

Can be adjusted between 0.037m/s – 0.29m/s

Use the ROEQ GuardCom for additional safety when transferring loads





Product no.	Product name	Description	
265a5200	TR125 Manual	Top Roller with manual height adjustment for MiR 100/200	
281a5200	TR125 Manual 250	Top Roller with manual height adjustment for MiR250	
273a1000	GuardCom	GuardCom unit to mount on stationary conveyor. Wireless communication, not using Wi-Fi	 
273a2000	GuardCom Connect	Communications unit to mount on top rollers. Wireless communication with GuardCom, not using Wi-Fi	
265a5040	DS Standalone	Floor mounted docking station for top roller series TR125, TR500 and TR1000	

Visit roeq.dk for more information or to see films of products in action.

Contact your local ROEQ Partner for more guidance